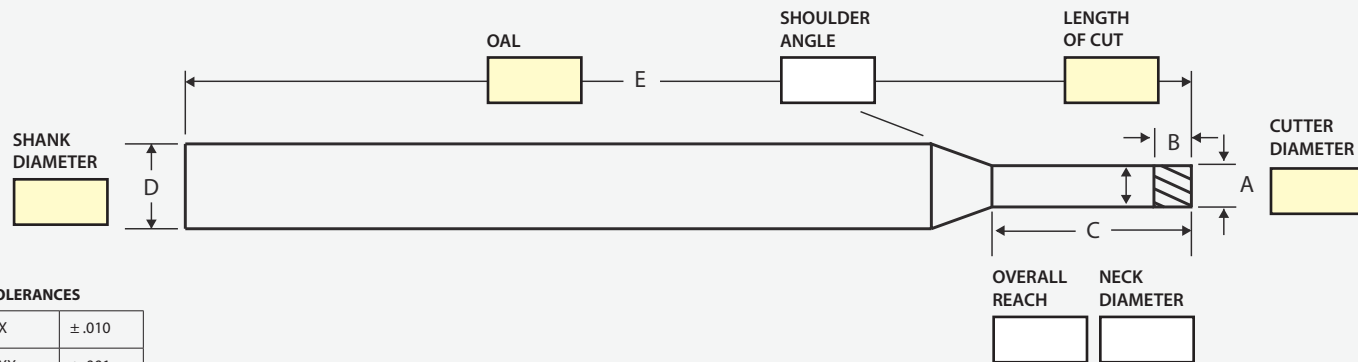

1. End Mill
2. Drill, Drill Mill, Spot Drill, G-Style Drill, Double Margin Drill
3. Reamer
4. Step Drill, Step Reamer
5. Thread Mill
6. Keyseat Cutter
7. Brazed and Arbor Mounted Saws
8. Drafted Mold Tool, Tapered End Mill
9. Clearance Cutter
10. Tapered Rib Cutter
11. Hard Milling End Mill, Shank-On Reduced-Neck End Mill
12. Undercutting End Mill, Cherry Ball Tool
13. Dovetail
14. Chamfer Cutter, Corner Rounder
15. Boring Bar
16. Deburring Knife
17. Engraving Tool
18. Rebar Tool, Thread Bar
19. Broach, Pin, Go/No-Go Gauge
20. Form Tool

TOLERANCES

.XX	± .010
.XXX	± .001
.XXXX	± .0005
Angular	± 1.0°

NOTES:

- Tolerances are quoted with block tolerance unless noted (excluding OAL).
- Shoulder angle is x° unless specified.
- All dimensions are inches unless noted.
- Diagram letters correspond with standard tool columns featured in MITGI product catalog.
- Use **highlighter** to designate cutting area.

Company Information

ORGANIZATION
PRIMARY CONTACT - NAME, EMAIL, PHONE
SECONDARY CONTACT - NAME, EMAIL, PHONE
ADDRESS
CITY, STATE, ZIP

Schedule and Production

DATE SUBMITTED
TARGET DELIVERY DATE
PREFERRED SHIPPING METHOD
LASER MARKING (Y / N)
SPECIAL NOTES OR INSTRUCTIONS

Tool Information

ITEM NUMBER
QUANTITY (QUANTITIES TO QUOTE)
MATERIAL MACHINING
NUMBER OF FLUTES
HELIX ANGLE
VARIABLE HELIX ANGLES (2 ANGLES NEEDED)

Tool Material (CIRCLE ONE)

CARBIDE	HSS	COOLANT THRU
PRE-FORM	SUPPLIED MAT'L	

Coating (CIRCLE ONE)

UNCOATED	ALTIN	TIN
TICN	NACRO [®]	NACRO [®]
DLC	DIAMOND	ZRN

End Finish (CIRCLE ONE, ADD NOTES)

SQUARE	RADIUS (R)	BALL
CHAMFER (DEGREE)	CHAMFER (FLAT)	

Quoting (MITGI USE ONLY)

MATERIAL STOCK OR SPECIAL ORDER
PRICING (BY QTY)
ESTIMATED SHIP DATE
MITGI CUSTOMER NUMBER
MITGI ACCOUNT MANAGER

GSS (MITGI USE ONLY)

PART DESCRIPTION CODE:	CUTTER DIAMETER/6
	# FLUTES/2
	TOOL TYPE CODE/4
	LOC/5
	SHANK DIAMETER/5
	OAL/3
PRODUCT CODE:	CB, CG

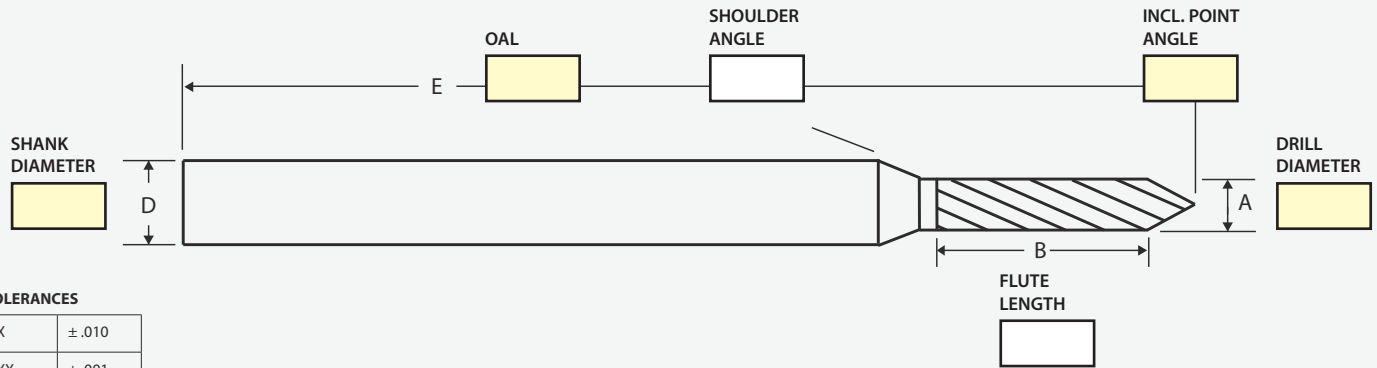
TOLERANCES

.XX	± .010
.XXX	± .001
.XXXX	± .0005
Angular	± 1.0°

NOTES:

1. Tolerances are quoted with block tolerance unless noted (excluding OAL).
2. Shoulder angle is x° unless specified.
3. All dimensions are inches unless noted.
4. Use **highlighter** to designate cutting area.
5. G-Style and Gun Drills are straight flute only.

Company Information

ORGANIZATION
PRIMARY CONTACT - NAME, EMAIL, PHONE
SECONDARY CONTACT - NAME, EMAIL, PHONE
ADDRESS
CITY, STATE, ZIP

Schedule and Production

DATE SUBMITTED
TARGET DELIVERY DATE
PREFERRED SHIPPING METHOD
LASER MARKING (Y / N)
SPECIAL NOTES OR INSTRUCTIONS

Tool Information

ITEM NUMBER
QUANTITY (QUANTITIES) TO QUOTE
MATERIAL MACHINING
NUMBER OF FLUTES
HELIX ANGLE (0° = STRAIGHT)

Tool Material (CIRCLE ONE)

CARBIDE	HSS	COOLANT THRU
PRE-FORM	SUPPLIED MAT'L	

Coating (CIRCLE ONE)

UNCOATED	ALTIN	TIN
TICN	NACO®	NACRO®
DLC	DIAMOND	ZRN

End Finish (CIRCLE ONE)

STD. DRILL	DOUBLE MARGIN	SPOT DRILL
DRILL MILL	G-STYLE	OTHER

Quoting (MITGI USE ONLY)

MATERIAL STOCK OR SPECIAL ORDER
PRICING (BY QTY)
ESTIMATED SHIP DATE
MITGI CUSTOMER NUMBER
MITGI ACCOUNT MANAGER

GSS (MITGI USE ONLY)

PART DESCRIPTION CODE:	CUTTER DIAMETER/6
	# FLUTES/2
	TOOL TYPE CODE/4
	LOC/5
	SHANK DIAMETER/5
	OAL/3
	PRODUCT CODE: CC, CH

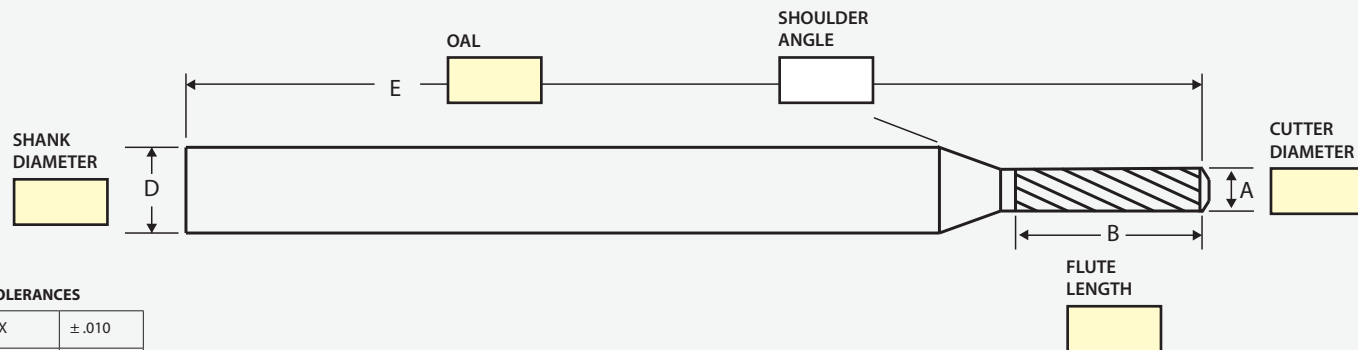
TOLERANCES

.XX	± .010
.XXX	± .001
.XXXX	± .0005
Angular	± 1.0°

NOTES:

- Tolerances are quoted with block tolerance unless noted (excluding OAL).
- Shoulder angle is x° unless specified.
- All dimensions are inches unless noted.
- Diagram letters correspond with standard tool columns featured in MITGI product catalog.
- Use **highlighter** to designate cutting area.

Company Information

ORGANIZATION
PRIMARY CONTACT - NAME, EMAIL, PHONE
SECONDARY CONTACT - NAME, EMAIL, PHONE
ADDRESS
CITY, STATE, ZIP

Schedule and Production

DATE SUBMITTED
TARGET DELIVERY DATE
PREFERRED SHIPPING METHOD
LASER MARKING (Y / N)
SPECIAL NOTES OR INSTRUCTIONS

Tool Information

ITEM NUMBER
QUANTITY (QUANTITIES TO QUOTE)
MATERIAL MACHINING
NUMBER OF FLUTES
HELIX ANGLE (0° = STRAIGHT)

Tool Material (CIRCLE ONE)

CARBIDE	HSS	COOLANT THRU
PRE-FORM	SUPPLIED MAT'L	

Coating (CIRCLE ONE)

UNCOATED	ALTiN	TiN
TiCN	NACo®	NACRO®
DLC	DIAMOND	ZRN

End Finish (CIRCLE ONE, ADD NOTES)

CHAMFER (ANGLE)	BALL	RADIUS (R)
-----------------	------	------------

Quoting (MITGI USE ONLY)

MATERIAL STOCK OR SPECIAL ORDER
PRICING (BY QTY)
ESTIMATED SHIP DATE
MITGI CUSTOMER NUMBER
MITGI ACCOUNT MANAGER

GSS (MITGI USE ONLY)

PART DESCRIPTION CODE:	CUTTER DIAMETER/6
	# FLUTES/2
	TOOL TYPE CODE/4 REAM
	LOC/5
	SHANK DIAMETER/5
	OAL/3
	PRODUCT CODE: CD, CI

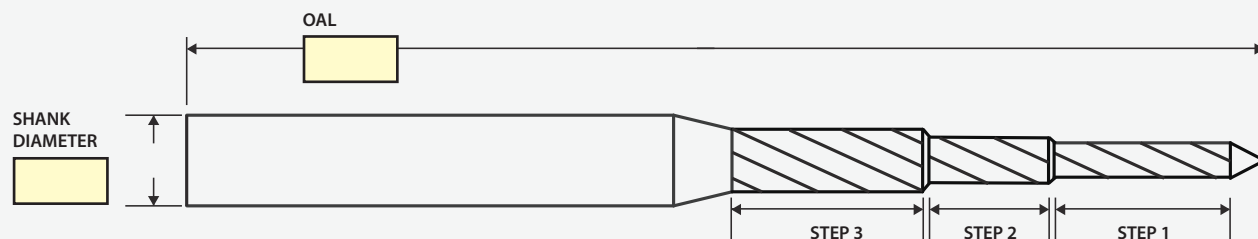
TOLERANCES

.XX	± .010
.XXX	± .001
.XXXX	± .0005
Angular	± 1.0°

	DIAMETER	LENGTH	SHOULDER ANGLE
STEP 1			
STEP 2			
STEP 3			

NOTES:

1. Tolerances are quoted with block tolerance unless noted (excluding OAL).
2. Shoulder angle is x° unless specified.
3. All dimensions are inches unless noted.
4. Use **highlighter** to designate cutting area.

Company Information

ORGANIZATION
PRIMARY CONTACT - NAME, EMAIL, PHONE
SECONDARY CONTACT - NAME, EMAIL, PHONE
ADDRESS
CITY, STATE, ZIP

Schedule and Production

DATE SUBMITTED
TARGET DELIVERY DATE
PREFERRED SHIPPING METHOD
LASER MARKING (Y / N)
SPECIAL NOTES OR INSTRUCTIONS

Tool Information

ITEM NUMBER
QUANTITY (QUANTITIES TO QUOTE)
MATERIAL MACHINING
NUMBER OF FLUTES
HELIX ANGLE (0° = STRAIGHT)

Tool Material (CIRCLE ONE)

CARBIDE	HSS	COOLANT THRU
PRE-FORM	SUPPLIED MAT'L	

Coating (CIRCLE ONE)

UNCOATED	ALTiN	TiN
TiCN	NACO®	NACRO®
DLC	DIAMOND	ZrN

End Finish (CIRCLE ONE, ADD NOTES)

REAMER (DEGREE)	DRILL (INCL. ANGLE)	OTHER
-----------------	---------------------	-------

Quoting (MITGI USE ONLY)

MATERIAL STOCK OR SPECIAL ORDER
PRICING (BY QTY)
ESTIMATED SHIP DATE
MITGI CUSTOMER NUMBER
MITGI ACCOUNT MANAGER

GSS (MITGI USE ONLY)

PART DESCRIPTION CODE:	CUTTER DIAMETER/6
	# FLUTES/2
	TOOL TYPE CODE/4 SDRL, SREA
	LOC/5
	SHANK DIAMETER/5
	OAL/3
	PRODUCT CODE: CC, CD, CH, CI

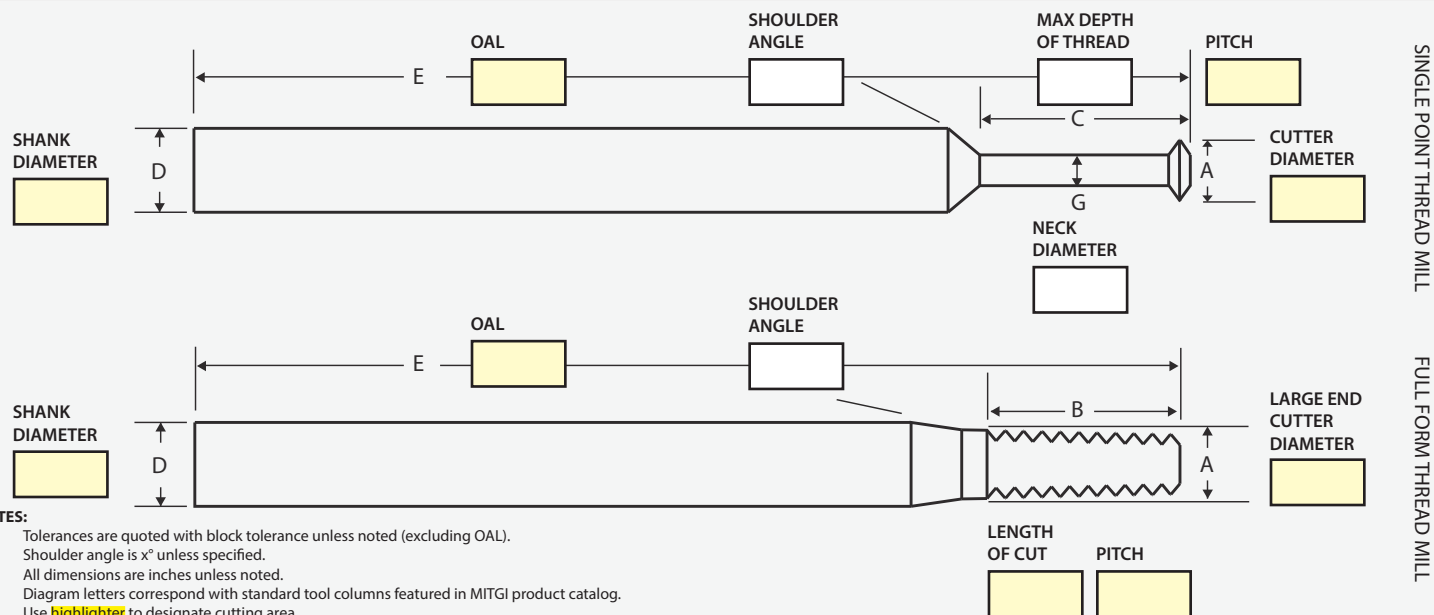

Company Information

ORGANIZATION
PRIMARY CONTACT - NAME, EMAIL, PHONE
SECONDARY CONTACT - NAME, EMAIL, PHONE
ADDRESS
CITY, STATE, ZIP

Schedule and Production

DATE SUBMITTED
TARGET DELIVERY DATE
PREFERRED SHIPPING METHOD
LASER MARKING (Y / N)
SPECIAL NOTES OR INSTRUCTIONS

Tool Information

ITEM NUMBER
QUANTITY (QUANTITIES TO QUOTE)
MATERIAL MACHINING
NUMBER OF FLUTES
HELIX ANGLE (0° = STRAIGHT)
THREAD TYPE

Tool Material (CIRCLE ONE)

CARBIDE	HSS	COOLANT THRU
PRE-FORM	SUPPLIED MAT'L	

Coating (CIRCLE ONE)

UNCOATED	ALTiN	TiN
TiCN	NACRO®	NACRO®
DLC	DIAMOND	ZRN

TOLERANCES

.XX	± .010
.XXX	± .001
.XXXX	± .0005
Angular	± 1.0°

Quoting (MITGI USE ONLY)

MATERIAL STOCK OR SPECIAL ORDER
PRICING (BY QTY)
ESTIMATED SHIP DATE
MITGI CUSTOMER NUMBER
MITGI ACCOUNT MANAGER

GSS (MITGI USE ONLY)

PART DESCRIPTION CODE:	CUTTER DIAMETER/6
	# FLUTES/2
	TOOL TYPE CODE/4 TRDM
	LOC/5
	SHANK DIAMETER/5
	OAL/3
	PRODUCT CODE: CE, CJ

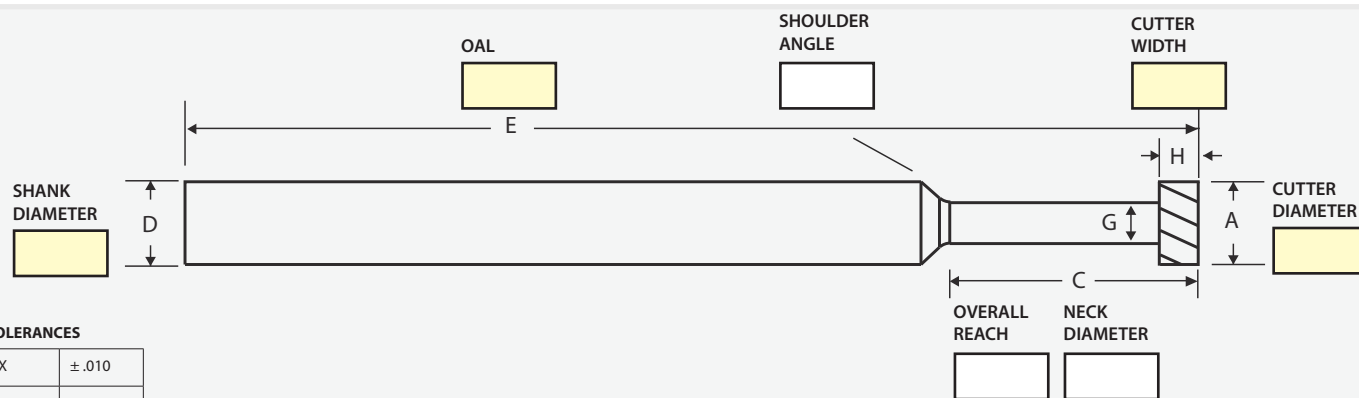
TOLERANCES

.XX	± .010
.XXX	± .001
.XXXX	± .0005
Angular	± 1.0°

NOTES:

- Tolerances are quoted with block tolerance unless noted (excluding OAL).
- Shoulder angle is x° unless specified.
- All dimensions are inches unless noted.
- Diagram letters correspond with standard tool columns featured in MITGI product catalog.
- Use **highlighter** to designate cutting area.

Company Information

ORGANIZATION
PRIMARY CONTACT - NAME, EMAIL, PHONE
SECONDARY CONTACT - NAME, EMAIL, PHONE
ADDRESS
CITY, STATE, ZIP

Schedule and Production

DATE SUBMITTED
TARGET DELIVERY DATE
PREFERRED SHIPPING METHOD
LASER MARKING (Y / N)
SPECIAL NOTES OR INSTRUCTIONS

Tool Information

ITEM NUMBER
QUANTITY (QUANTITIES TO QUOTE)
MATERIAL MACHINING
NUMBER OF TEETH
HELIX ANGLE (0° = STRAIGHT)

Tool Material (CIRCLE ONE)

CARBIDE	HSS	COOLANT THRU
PRE-FORM	SUPPLIED MAT'L	

Coating (CIRCLE ONE)

UNCOATED	ALTiN	TiN
TiCN	NACRO®	NACRO®
DLC	DIAMOND	ZrN

End Finish (CIRCLE ONE, ADD NOTES)

SQUARE	CORNER RADIUS (R)	FULL RADIUS
CHAMFER (DEGREE)	CHAMFER (FLAT)	

Quoting (MITGI USE ONLY)

MATERIAL STOCK OR SPECIAL ORDER
PRICING (BY QTY)
ESTIMATED SHIP DATE
MITGI CUSTOMER NUMBER
MITGI ACCOUNT MANAGER

GSS (MITGI USE ONLY)

PART DESCRIPTION CODE:	CUTTER DIAMETER/6
	# FLUTES/2
	TOOL TYPE CODE/4 KEYS
	LOC/5
	SHANK DIAMETER/5
	OAL/3
	PRODUCT CODE: CA, CF

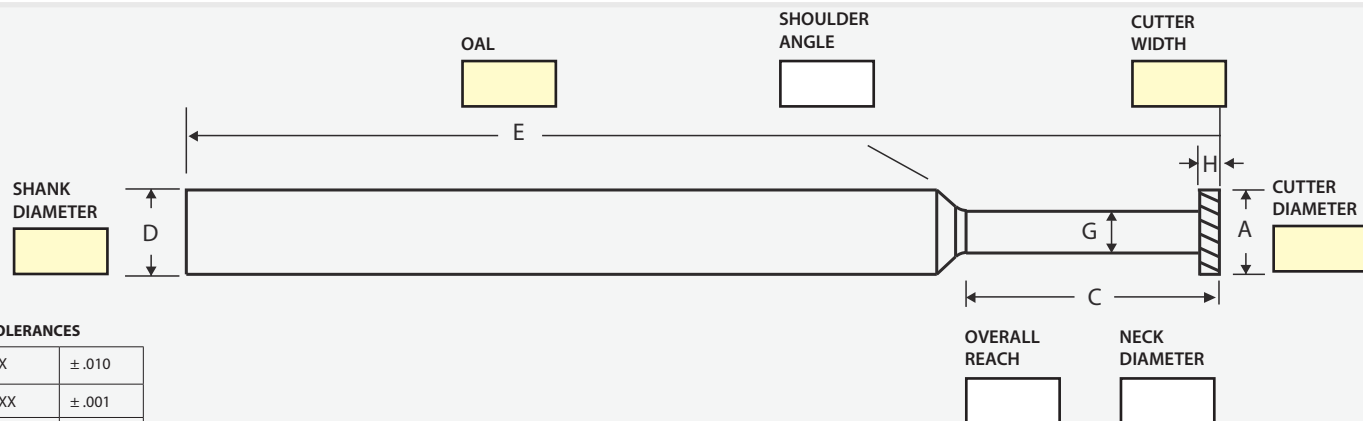
TOLERANCES

.XX	± .010
.XXX	± .001
.XXXX	± .0005
Angular	± 1.0°

NOTES:

1. Tolerances are quoted with block tolerance unless noted (excluding OAL).
2. Shoulder angle is x° unless specified.
3. All dimensions are inches unless noted.
4. Diagram letters correspond with standard tool columns featured in MITGI product catalog.
5. Use **highlighter** to designate cutting area.

Company Information

ORGANIZATION
PRIMARY CONTACT - NAME, EMAIL, PHONE
SECONDARY CONTACT - NAME, EMAIL, PHONE
ADDRESS
CITY, STATE, ZIP

Schedule and Production

DATE SUBMITTED
TARGET DELIVERY DATE
PREFERRED SHIPPING METHOD
LASER MARKING (Y / N)
SPECIAL NOTES OR INSTRUCTIONS

Tool Information

ITEM NUMBER
QUANTITY (QUANTITIES TO QUOTE)
MATERIAL MACHINING
NUMBER OF TEETH
HELIX ANGLE (0° = STRAIGHT)
SAW TYPE: ARBOR MOUNTED (INCL. CENTER DIAMETER) OR BRAZED

Tool Material (CIRCLE ONE)

CARBIDE	HSS
PRE-FORM	SUPPLIED MAT'L

Coating (CIRCLE ONE)

UNCOATED	ALTIN	TIN
TICN	NACO [®]	NACRO [®]
DLC	DIAMOND	ZRN

End Finish (CIRCLE ONE, ADD NOTES)

SQUARE	CORNER RADIUS	FULL RADIUS
CHAMFER (DEGREE)	CHAMFER (FLAT)	

Quoting (MITGI USE ONLY)

MATERIAL STOCK OR SPECIAL ORDER
PRICING (BY QTY)
ESTIMATED SHIP DATE
MITGI CUSTOMER NUMBER
MITGI ACCOUNT MANAGER

GSS (MITGI USE ONLY)

PART DESCRIPTION CODE:	CUTTER DIAMETER/6
	# FLUTES/2
	TOOL TYPE CODE/4 SAWS
	LOC/5
	SHANK DIAMETER/5
	OAL/3
	PRODUCT CODE: CA, CF

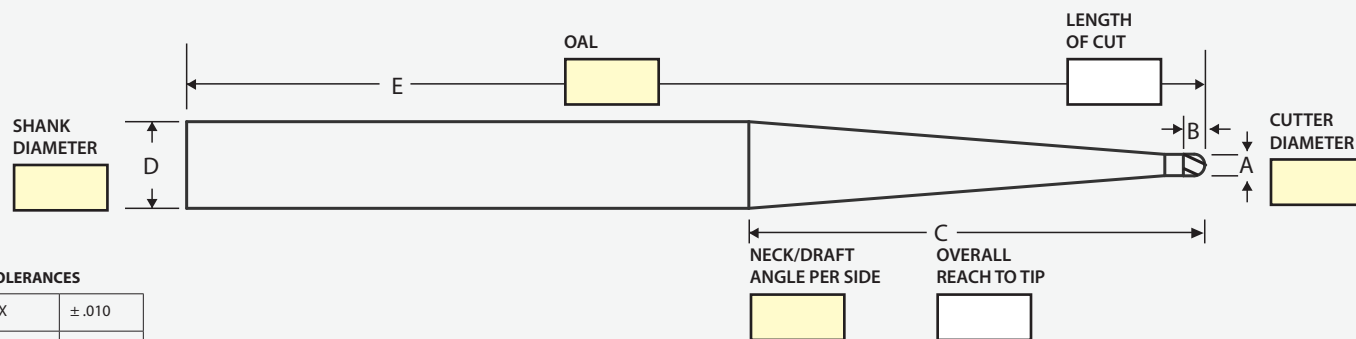
TOLERANCES

.XX	± .010
.XXX	± .001
.XXXX	± .0005
Angular	± 1.0°

NOTES:

- Tolerances are quoted with block tolerance unless noted (excluding OAL).
- Shoulder angle is x° unless specified.
- All dimensions are inches unless noted.
- Diagram letters correspond with standard tool columns featured in MITGI product catalog.
- Use **highlighter** to designate cutting area.

Company Information

ORGANIZATION
PRIMARY CONTACT - NAME, EMAIL, PHONE
SECONDARY CONTACT - NAME, EMAIL, PHONE
ADDRESS
CITY, STATE, ZIP

Schedule and Production

DATE SUBMITTED
TARGET DELIVERY DATE
PREFERRED SHIPPING METHOD
LASER MARKING (Y / N)
SPECIAL NOTES OR INSTRUCTIONS

Tool Information

ITEM NUMBER
QUANTITY (QUANTITIES TO QUOTE)
MATERIAL MACHINING
NUMBER OF FLUTES
HELIX ANGLE
VARIABLE HELIX ANGLES (2 ANGLES NEEDED)

Tool Material (CIRCLE ONE)

CARBIDE	HSS
PRE-FORM	SUPPLIED MAT'L

Coating (CIRCLE ONE)

UNCOATED	ALTIN	TIN
TICN	NACRO [®]	NACRO [®]
DLC	DIAMOND	ZRN

End Finish (CIRCLE ONE, ADD NOTES)

SQUARE	RADIUS (R)	BALL
CHAMFER (DEGREE)	CHAMFER (FLAT)	

Quoting (MITGI USE ONLY)

MATERIAL STOCK OR SPECIAL ORDER
PRICING (BY QTY)
ESTIMATED SHIP DATE
MITGI CUSTOMER NUMBER
MITGI ACCOUNT MANAGER

GSS (MITGI USE ONLY)

PART DESCRIPTION CODE:	CUTTER DIAMETER/6
	# FLUTES/2
	TOOL TYPE CODE/4
	LOC/5
	SHANK DIAMETER/5
	OAL/3
PRODUCT CODE:	CK, CB, CG

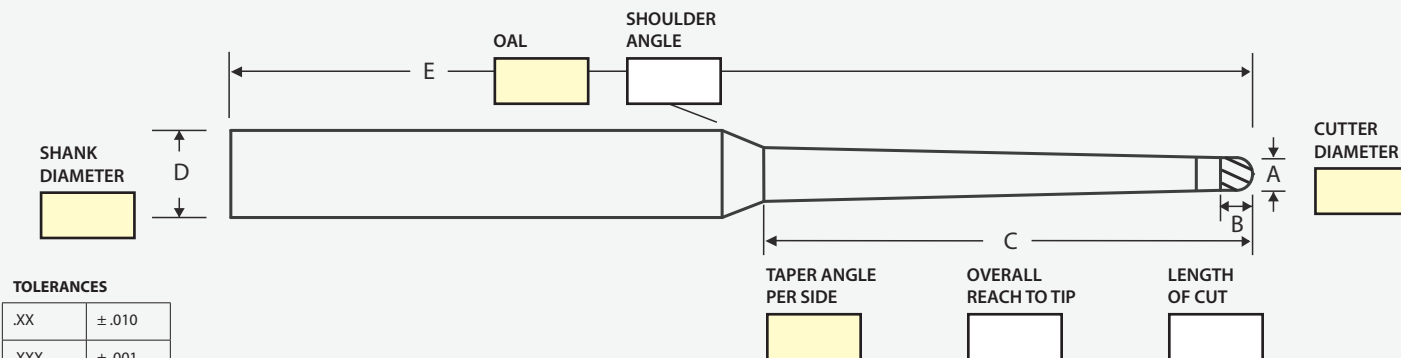
TOLERANCES

.XX	± .010
.XXX	± .001
.XXXX	± .0005
Angular	± 1.0°

NOTES:

1. Tolerances are quoted with block tolerance unless noted (excluding OAL).
2. Shoulder angle is x° unless specified.
3. All dimensions are inches unless noted.
4. Diagram letters correspond with standard tool columns featured in MITGI product catalog.
5. Use **highlighter** to designate cutting area.

Company Information

ORGANIZATION
PRIMARY CONTACT - NAME, EMAIL, PHONE
SECONDARY CONTACT - NAME, EMAIL, PHONE
ADDRESS
CITY, STATE, ZIP

Schedule and Production

DATE SUBMITTED
TARGET DELIVERY DATE
PREFERRED SHIPPING METHOD
LASER MARKING (Y / N)
SPECIAL NOTES OR INSTRUCTIONS

Tool Information

ITEM NUMBER
QUANTITY (QUANTITIES TO QUOTE)
MATERIAL MACHINING
NUMBER OF FLUTES
HELIX ANGLE
VARIABLE HELIX ANGLES (2 ANGLES NEEDED)

Tool Material (CIRCLE ONE)

CARBIDE	HSS
PRE-FORM	SUPPLIED MAT'L

Coating (CIRCLE ONE)

UNCOATED	ALTIN	TIN
TICN	NACRO [®]	NACRO [®]
DLC	DIAMOND	ZRN

End Finish (CIRCLE ONE, ADD NOTES)

SQUARE	RADIUS (R)	BALL
CHAMFER (DEGREE)	CHAMFER (FLAT)	

Quoting (MITGI USE ONLY)

MATERIAL STOCK OR SPECIAL ORDER
PRICING (BY QTY)
ESTIMATED SHIP DATE
MITGI CUSTOMER NUMBER
MITGI ACCOUNT MANAGER

GSS (MITGI USE ONLY)

PART DESCRIPTION CODE:	CUTTER DIAMETER/6
	# FLUTES/2
	TOOL TYPE CODE/4
	LOC/5
	SHANK DIAMETER/5
	OAL/3
PRODUCT CODE:	CK

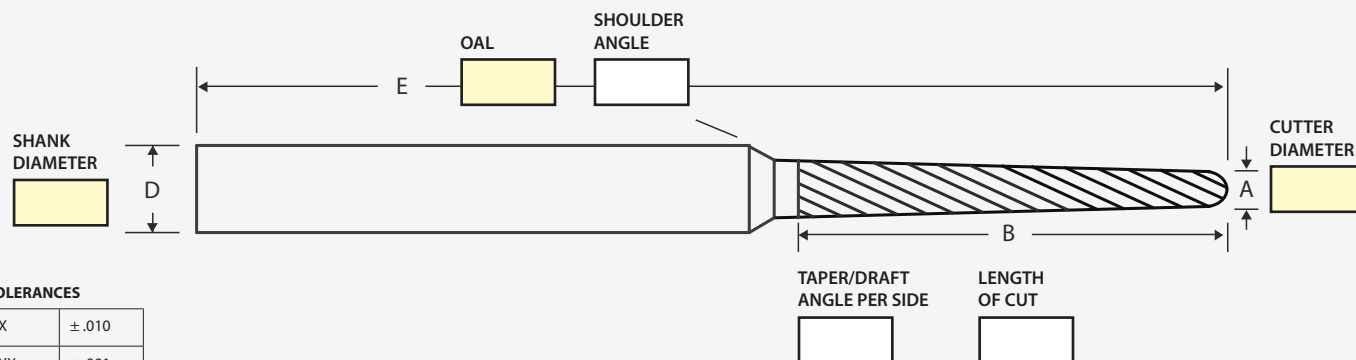
TOLERANCES

.XX	± .010
.XXX	± .001
.XXXX	± .0005
Angular	± 1.0°

NOTES:

1. Tolerances are quoted with block tolerance unless noted (excluding OAL).
2. Shoulder angle is x° unless specified.
3. All dimensions are inches unless noted.
4. Diagram letters correspond with standard tool columns featured in MITGI product catalog.
5. Use **highlighter** to designate cutting area.

Company Information

ORGANIZATION
PRIMARY CONTACT - NAME, EMAIL, PHONE
SECONDARY CONTACT - NAME, EMAIL, PHONE
ADDRESS
CITY, STATE, ZIP

Schedule and Production

DATE SUBMITTED
TARGET DELIVERY DATE
PREFERRED SHIPPING METHOD
LASER MARKING (Y / N)
SPECIAL NOTES OR INSTRUCTIONS

Tool Information

ITEM NUMBER
QUANTITY (QUANTITIES TO QUOTE)
MATERIAL MACHINING
NUMBER OF FLUTES
HELIX ANGLE
VARIABLE HELIX ANGLES (2 ANGLES NEEDED)

Tool Material (CIRCLE ONE)

CARBIDE	HSS
PRE-FORM	SUPPLIED MAT'L

Coating (CIRCLE ONE)

UNCOATED	ALTIN	TIN
TICN	NACO®	NACRO®
DLC	DIAMOND	ZRN

End Finish (CIRCLE ONE, ADD NOTES)

SQUARE	RADIUS (R)	BALL
CHAMFER (DEGREE)	CHAMFER (FLAT)	

Quoting (MITGI USE ONLY)

MATERIAL STOCK OR SPECIAL ORDER
PRICING (BY QTY)
ESTIMATED SHIP DATE
MITGI CUSTOMER NUMBER
MITGI ACCOUNT MANAGER

GSS (MITGI USE ONLY)

PART DESCRIPTION CODE:	CUTTER DIAMETER/6
	# FLUTES/2
	TOOL TYPE CODE/4
	LOC/5
	SHANK DIAMETER/5
	OAL/3
PRODUCT CODE:	CK

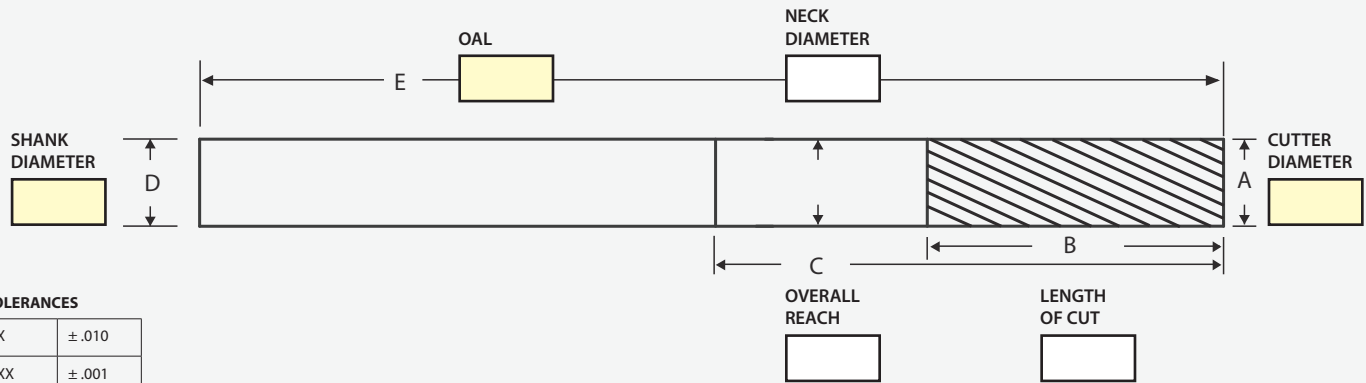
TOLERANCES

.XX	± .010
.XXX	± .001
.XXXX	± .0005
Angular	± 1.0°

NOTES:

1. Tolerances are quoted with block tolerance unless noted (excluding OAL).
2. Shoulder angle is x° unless specified.
3. All dimensions are inches unless noted.
4. Diagram letters correspond with standard tool columns featured in MITGI product catalog.
5. Use **highlighter** to designate cutting area.

Company Information

ORGANIZATION

PRIMARY CONTACT - NAME, EMAIL, PHONE

SECONDARY CONTACT - NAME, EMAIL, PHONE

ADDRESS

CITY, STATE, ZIP

Schedule and Production

DATE SUBMITTED

TARGET DELIVERY DATE

PREFERRED SHIPPING METHOD

LASER MARKING (Y / N)

SPECIAL NOTES OR INSTRUCTIONS

Tool Information

ITEM NUMBER

QUANTITY (QUANTITIES TO QUOTE)

MATERIAL MACHINING

NUMBER OF FLUTES

HELIX ANGLE

VARIABLE HELIX ANGLES (2 ANGLES NEEDED)

Tool Material (CIRCLE ONE)

CARBIDE	HSS	COOLANT THRU
PRE-FORM	SUPPLIED MAT'L	

Coating (CIRCLE ONE)

UNCOATED	ALTIN	TIN
TICN	NACRO [®]	NACRO [®]
DLC	DIAMOND	ZRN

End Finish (CIRCLE ONE, ADD NOTES)

SQUARE	RADIUS (R)	BALL
CHAMFER (DEGREE)	CHAMFER (FLAT)	

Quoting (MITGI USE ONLY)

MATERIAL STOCK OR SPECIAL ORDER

PRICING (BY QTY)

ESTIMATED SHIP DATE

MITGI CUSTOMER NUMBER

MITGI ACCOUNT MANAGER

GSS (MITGI USE ONLY)

PART DESCRIPTION CODE: CUTTER DIAMETER/6

FLUTES/2

TOOL TYPE CODE/4

LOC/5

SHANK DIAMETER/5

OAL/3

 PRODUCT CODE:
 CK, CB, CG

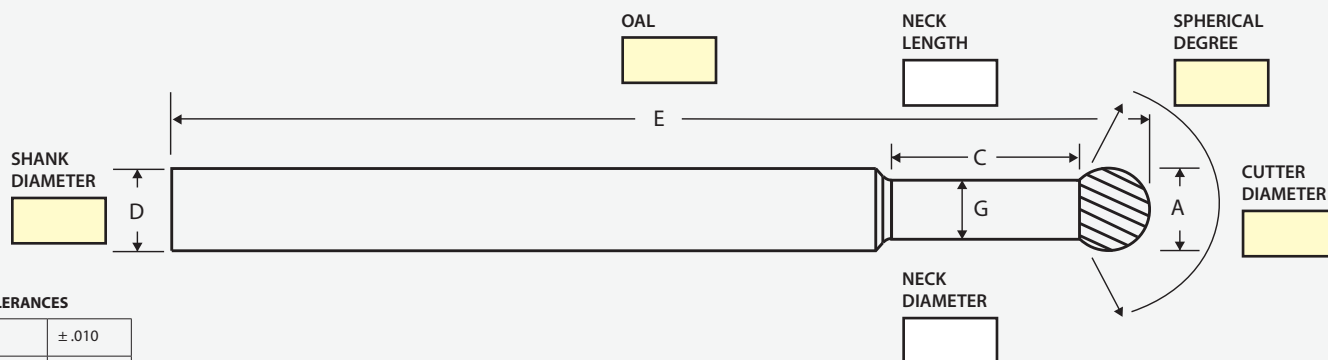
TOLERANCES

.XX	± .010
.XXX	± .001
.XXXX	± .0005
Angular	± 1.0°

NOTES:

- Tolerances are quoted with block tolerance unless noted (excluding OAL).
- Shoulder angle is x° unless specified.
- All dimensions are inches unless noted.
- Diagram letters correspond with standard tool columns featured in MITGI product catalog.
- Use **highlighter** to designate cutting area.

Company Information

ORGANIZATION
PRIMARY CONTACT - NAME, EMAIL, PHONE
SECONDARY CONTACT - NAME, EMAIL, PHONE
ADDRESS
CITY, STATE, ZIP

Schedule and Production

DATE SUBMITTED
TARGET DELIVERY DATE
PREFERRED SHIPPING METHOD
LASER MARKING (Y / N)
SPECIAL NOTES OR INSTRUCTIONS

Tool Information

ITEM NUMBER
QUANTITY (QUANTITIES TO QUOTE)
MATERIAL MACHINING
NUMBER OF FLUTES
HELIX ANGLE (0° = STRAIGHT)
VARIABLE HELIX ANGLES (2 ANGLES NEEDED)

Tool Material (CIRCLE ONE)

CARBIDE	HSS
PRE-FORM	SUPPLIED MAT'L

Coating (CIRCLE ONE)

UNCOATED	ALTIN	TIN
TICN	NACO®	NACRO®
DLC	DIAMOND	ZRN

Quoting (MITGI USE ONLY)

MATERIAL STOCK OR SPECIAL ORDER
PRICING (BY QTY)
ESTIMATED SHIP DATE
MITGI CUSTOMER NUMBER
MITGI ACCOUNT MANAGER

GSS (MITGI USE ONLY)

PART DESCRIPTION CODE:	CUTTER DIAMETER/6
	# FLUTES/2
	TOOL TYPE CODE/4 CHRY
	LOC/5
	SHANK DIAMETER/5
	OAL/3
	PRODUCT CODE: CA

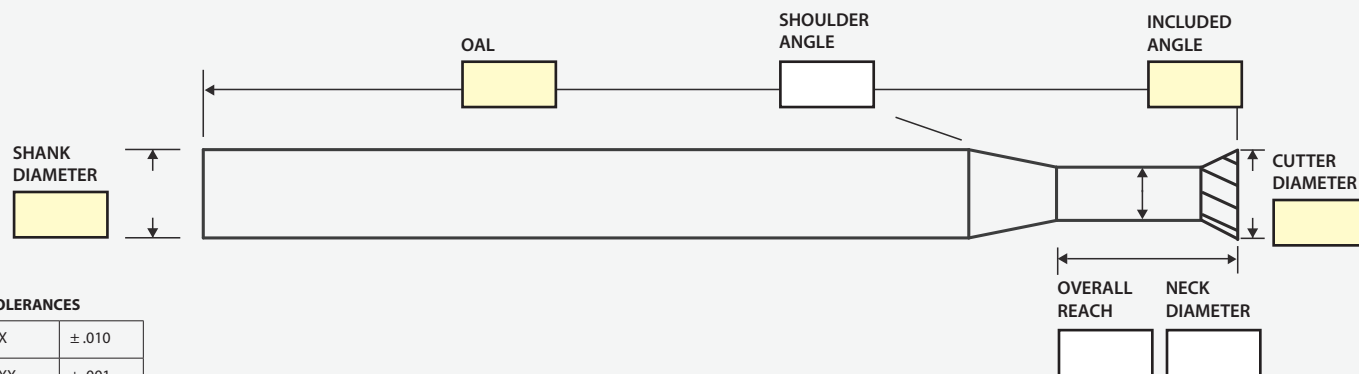
TOLERANCES

.XX	± .010
.XXX	± .001
.XXXX	± .0005
Angular	± 1.0°

NOTES:

1. Tolerances are quoted with block tolerance unless noted (excluding OAL).
2. Shoulder angle is x° unless specified.
3. All dimensions are inches unless noted.
4. Use **highlighter** to designate cutting area.

Company Information

ORGANIZATION
PRIMARY CONTACT - NAME, EMAIL, PHONE
SECONDARY CONTACT - NAME, EMAIL, PHONE
ADDRESS
CITY, STATE, ZIP

Schedule and Production

DATE SUBMITTED
TARGET DELIVERY DATE
PREFERRED SHIPPING METHOD
LASER MARKING (Y / N)
SPECIAL NOTES OR INSTRUCTIONS

Tool Information

ITEM NUMBER
QUANTITY (QUANTITIES TO QUOTE)
MATERIAL MACHINING
NUMBER OF FLUTES
HELIX ANGLE (0° = STRAIGHT)
VARIABLE HELIX ANGLES (2 ANGLES NEEDED)

Tool Material (CIRCLE ONE)

CARBIDE	HSS	COOLANT THRU
PRE-FORM	SUPPLIED MAT'L	

Coating (CIRCLE ONE)

UNCOATED	ALTIN	TIN
TICN	NACO®	NACRO®
DLC	DIAMOND	ZRN

End Finish (CIRCLE ONE, ADD NOTES)

SHARP	CORNER RADIUS (R)
-------	-------------------

Quoting (MITGI USE ONLY)

MATERIAL STOCK OR SPECIAL ORDER
PRICING (BY QTY)
ESTIMATED SHIP DATE
MITGI CUSTOMER NUMBER
MITGI ACCOUNT MANAGER

GSS (MITGI USE ONLY)

PART DESCRIPTION CODE:	CUTTER DIAMETER/6
	# FLUTES/2
	TOOL TYPE CODE/4 DOVE
	LOC/5
	SHANK DIAMETER/5
	OAL/3
	PRODUCT CODE: CA

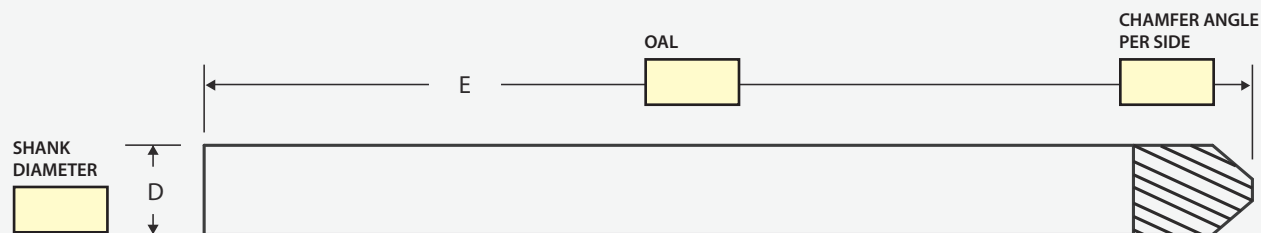
TOLERANCES

.XX	± .010
.XXX	± .001
.XXXX	± .0005
Angular	± 1.0°

NOTES:

1. Tolerances are quoted with block tolerance unless noted (excluding OAL).
2. Shoulder angle is x° unless specified.
3. All dimensions are inches unless noted.
4. Diagram letters correspond with standard tool columns featured in MITGI product catalog.
5. Use **highlighter** to designate cutting area.

Company Information

ORGANIZATION
PRIMARY CONTACT - NAME, EMAIL, PHONE
SECONDARY CONTACT - NAME, EMAIL, PHONE
ADDRESS
CITY, STATE, ZIP

Schedule and Production

DATE SUBMITTED
TARGET DELIVERY DATE
PREFERRED SHIPPING METHOD
LASER MARKING (Y / N)
SPECIAL NOTES OR INSTRUCTIONS

Tool Information

ITEM NUMBER
QUANTITY (QUANTITIES) TO QUOTE
MATERIAL MACHINING
NUMBER OF FLUTES
HELIX ANGLE (0° = STRAIGHT)

Tool Material (CIRCLE ONE)

CARBIDE	HSS
PRE-FORM	SUPPLIED MAT'L

Coating (CIRCLE ONE)

UNCOATED	ALTIN	TIN
TICN	NACO®	NACRO®
DLC	DIAMOND	ZRN

Chamfer Cutter (CIRCLE ONE, ADD NOTES)

FLAT (WIDTH)	POINTED
--------------	---------

Corner Rounder (ADD NOTES)

FLAT (WIDTH)	RADIUS (R)
--------------	------------

Quoting (MITGI USE ONLY)

MATERIAL STOCK OR SPECIAL ORDER
PRICING (BY QTY)
ESTIMATED SHIP DATE
MITGI CUSTOMER NUMBER
MITGI ACCOUNT MANAGER

GSS (MITGI USE ONLY)

PART DESCRIPTION CODE:	CUTTER DIAMETER/6
	# FLUTES/2
	TOOL TYPE CODE/4 CMIL, CORO
	LOC/5
	SHANK DIAMETER/5
	OAL/3
	PRODUCT CODE: CB, CG

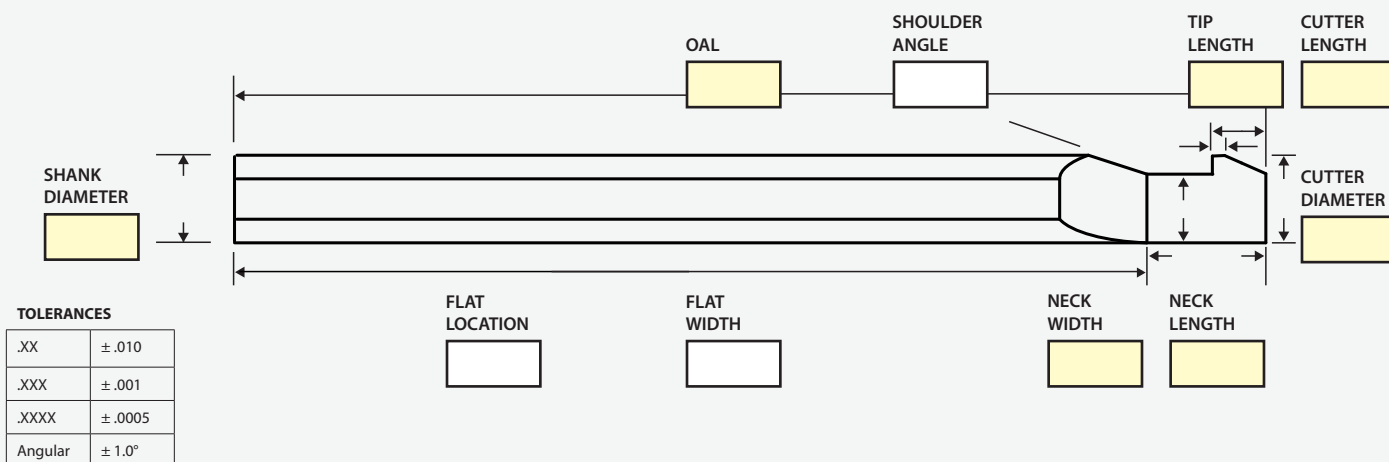

- NOTES:**
- Tolerances are quoted with block tolerance unless noted (excluding OAL).
 - Shoulder angle is x° unless specified.
 - All dimensions are inches unless noted.
 - Diagram letters correspond with standard tool columns featured in MITGI product catalog.
 - Use **highlighter** to designate cutting area.

Company Information

ORGANIZATION
PRIMARY CONTACT - NAME, EMAIL, PHONE
SECONDARY CONTACT - NAME, EMAIL, PHONE
ADDRESS
CITY, STATE, ZIP

Schedule and Production

DATE SUBMITTED
TARGET DELIVERY DATE
PREFERRED SHIPPING METHOD
LASER MARKING (Y / N)
SPECIAL NOTES OR INSTRUCTIONS

Tool Information

ITEM NUMBER
QUANTITY (QUANTITIES TO QUOTE)
MATERIAL MACHINING

Tool Material (CIRCLE ONE)

CARBIDE	HSS
PRE-FORM	SUPPLIED MAT'L

Coating (CIRCLE ONE)

UNCOATED	ALTIN	TIN
TICN	NACO®	NACRO®
DLC	DIAMOND	ZRN

End Finish (CIRCLE ONE, ADD NOTES)

SQUARE	RADIUS	BALL
SHARP (INCL. ANGLE)		

Quoting (MITGI USE ONLY)

MATERIAL STOCK OR SPECIAL ORDER
PRICING (BY QTY)
ESTIMATED SHIP DATE
MITGI CUSTOMER NUMBER
MITGI ACCOUNT MANAGER

GSS (MITGI USE ONLY)

PART DESCRIPTION CODE:	CUTTER DIAMETER/6
	# FLUTES/2 00
	TOOL TYPE CODE/4 BOBR
	LOC/5
	SHANK DIAMETER/5
	OAL/3
	PRODUCT CODE: CA, CF

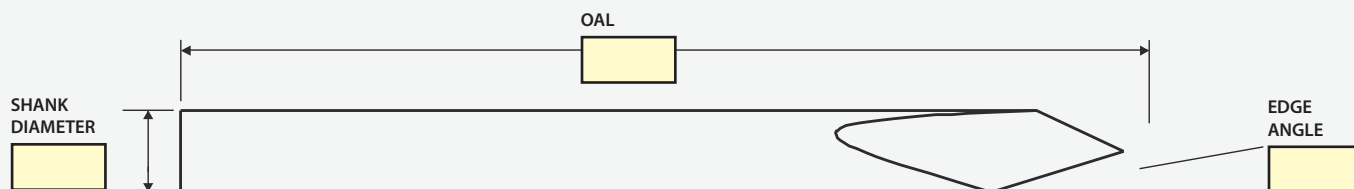
TOLERANCES

.XX	± .010
.XXX	± .001
.XXXX	± .0005
Angular	± 1.0°

NOTES:

1. Tolerances are quoted with block tolerance unless noted (excluding OAL).
2. Shoulder angle is x° unless otherwise specified.
3. All dimensions are inches unless noted.
4. Use **highlighter** to designate cutting area.

Company Information

ORGANIZATION
PRIMARY CONTACT - NAME, EMAIL, PHONE
SECONDARY CONTACT - NAME, EMAIL, PHONE
ADDRESS
CITY, STATE, ZIP

Schedule and Production

DATE SUBMITTED
TARGET DELIVERY DATE
PREFERRED SHIPPING METHOD
LASER MARKING (Y / N)
SPECIAL NOTES OR INSTRUCTIONS

Tool Information

ITEM NUMBER
QUANTITY (QUANTITIES) TO QUOTE
MATERIAL MACHINING
NUMBER OF FACETS OR SIDES

Tool Material (CIRCLE ONE)

CARBIDE	HSS	SUPPLIED MAT'L
---------	-----	----------------

Coating (CIRCLE ONE)

UNCOATED	ALTIN	TIN
TICN	NACO®	NACRO®
DLC	DIAMOND	ZRN

Quoting (MITGI USE ONLY)

MATERIAL STOCK OR SPECIAL ORDER
PRICING (BY QTY)
ESTIMATED SHIP DATE
MITGI CUSTOMER NUMBER
MITGI ACCOUNT MANAGER

GSS (MITGI USE ONLY)

PART DESCRIPTION CODE:	CUTTER DIAMETER/6
	# FLUTES/2 00
	TOOL TYPE CODE/4 DEBR
	LOC/5
	SHANK DIAMETER/5
	OAL/3
	PRODUCT CODE: CA, CF

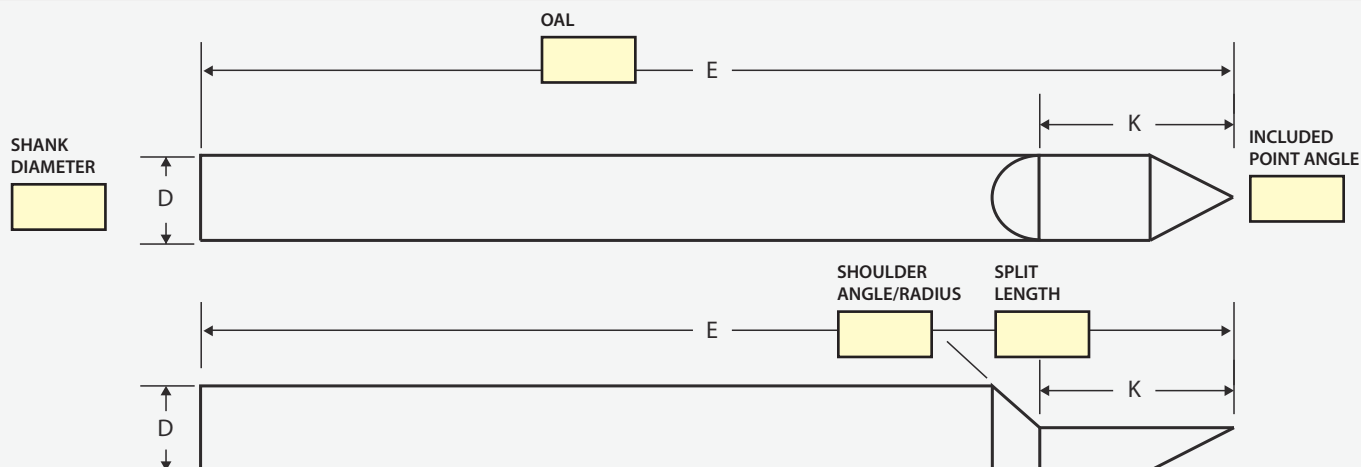
NOTES:

1. Tolerances are quoted with block tolerance unless noted (excluding OAL).
2. Shoulder angle is x° unless specified.
3. All dimensions are inches unless noted.
4. Diagram letters correspond with standard tool columns featured in MITGI product catalog.
5. Use **highlighter** to designate cutting area.

Company Information

ORGANIZATION
PRIMARY CONTACT - NAME, EMAIL, PHONE
SECONDARY CONTACT - NAME, EMAIL, PHONE
ADDRESS
CITY, STATE, ZIP

Schedule and Production

DATE SUBMITTED
TARGET DELIVERY DATE
PREFERRED SHIPPING METHOD
LASER MARKING (Y / N)
SPECIAL NOTES OR INSTRUCTIONS

Tool Information

ITEM NUMBER
QUANTITY (QUANTITIES) TO QUOTE
MATERIAL MACHINING

Tool Material (CIRCLE ONE)

CARBIDE	HSS	COOLANT THRU
PRE-FORM	SUPPLIED MAT'L	

Coating (CIRCLE ONE)

UNCOATED	ALTIN	TIN
TICN	NACO®	NACRO®
DLC	DIAMOND	ZRN

End Finish (CIRCLE ONE, ADD NOTES)

FLAT (WIDTH)	POINTED	RADIUS (R)
--------------	---------	------------

TOLERANCES

.XX	± .010
.XXX	± .001
.XXXX	± .0005
Angular	± 1.0°

Quoting (MITGI USE ONLY)

MATERIAL STOCK OR SPECIAL ORDER
PRICING (BY QTY)
ESTIMATED SHIP DATE
MITGI CUSTOMER NUMBER
MITGI ACCOUNT MANAGER

GSS (MITGI USE ONLY)

PART DESCRIPTION CODE:	CUTTER DIAMETER/6
	# FLUTES/2 00
	TOOL TYPE CODE/4 ENGR
	LOC/5
	SHANK DIAMETER/5
	OAL/3
	PRODUCT CODE: CA, CF

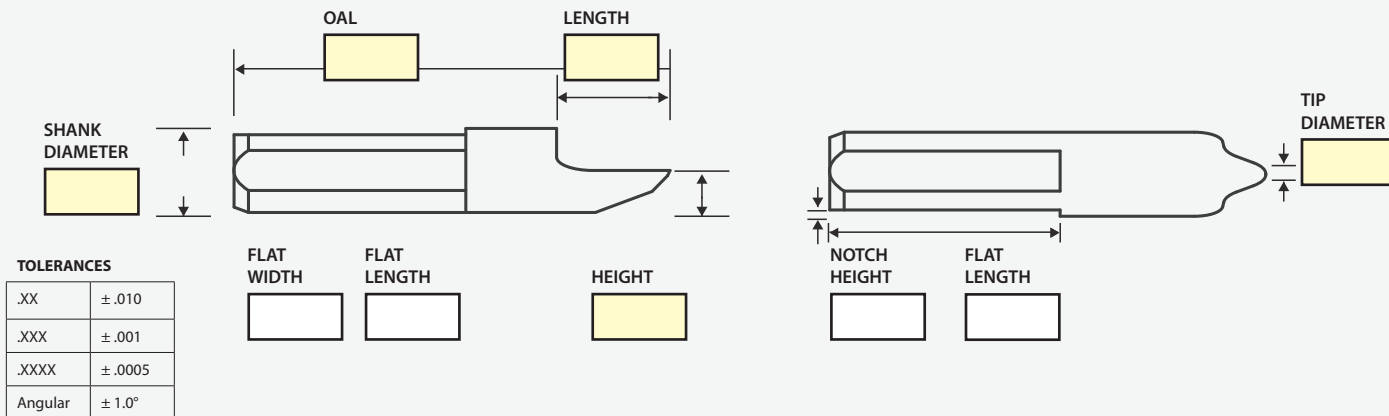

- NOTES:**
- Tolerances are quoted with block tolerance unless noted (excluding OAL).
 - Shoulder angle is x° unless specified.
 - All dimensions are inches unless noted.
 - Use **highlighter** to designate cutting area.

Company Information

ORGANIZATION
PRIMARY CONTACT - NAME, EMAIL, PHONE
SECONDARY CONTACT - NAME, EMAIL, PHONE
ADDRESS
CITY, STATE, ZIP

Schedule and Production

DATE SUBMITTED
TARGET DELIVERY DATE
PREFERRED SHIPPING METHOD
LASER MARKING (Y / N)
SPECIAL NOTES OR INSTRUCTIONS

Tool Information

ITEM NUMBER
QUANTITY (QUANTITIES) TO QUOTE
MATERIAL MACHINING
NUMBER OF FLATS ON SHANK
REBAR NUMBER/THREAD

Tool Material (CIRCLE ONE)

CARBIDE	HSS
PRE-FORM	SUPPLIED MAT'L

Coating (CIRCLE ONE)

UNCOATED	ALTiN	TiN
TiCN	NACo®	NACRO®
DLC	DIAMOND	ZrN

End Finish (CIRCLE ONE, ADD NOTES)

FLAT (WIDTH)	RADIUS (R)	BALL
OTHER		

Quoting (MITGI USE ONLY)

MATERIAL STOCK OR SPECIAL ORDER
PRICING (BY QTY)
ESTIMATED SHIP DATE
MITGI CUSTOMER NUMBER
MITGI ACCOUNT MANAGER

GSS (MITGI USE ONLY)

PART DESCRIPTION CODE:	CUTTER DIAMETER/6
# FLUTES/2	00
TOOL TYPE CODE/4	RBAR
LOC/5	
SHANK DIAMETER/5	
OAL/3	
PRODUCT CODE:	CA, CF

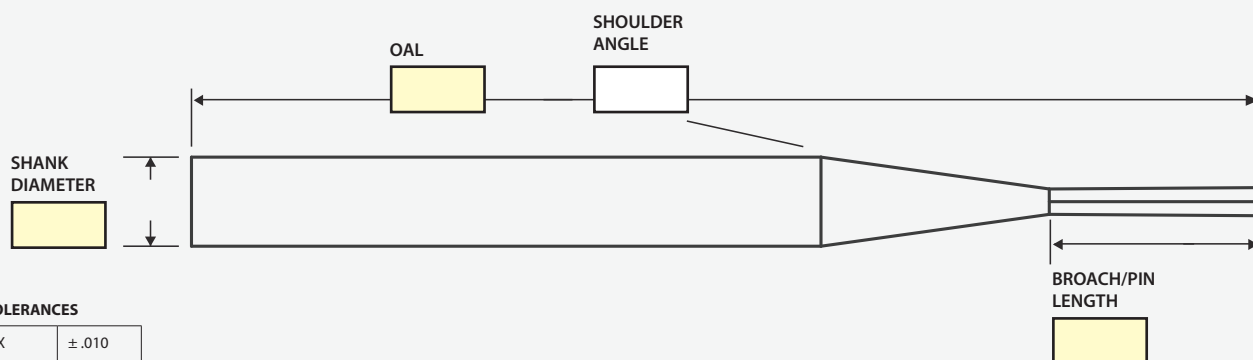
TOLERANCES

.XX	± .010
.XXX	± .001
.XXXX	± .0005
Angular	± 1.0°

NOTES:

1. Tolerances are quoted with block tolerance unless noted (excluding OAL).
2. Shoulder angle is x° unless specified.
3. All dimensions are inches unless noted.
4. Use **highlighter** to designate cutting area.

Company Information

ORGANIZATION
PRIMARY CONTACT - NAME, EMAIL, PHONE
SECONDARY CONTACT - NAME, EMAIL, PHONE
ADDRESS
CITY, STATE, ZIP

Schedule and Production

DATE SUBMITTED
TARGET DELIVERY DATE
PREFERRED SHIPPING METHOD
LASER MARKING (Y / N)
SPECIAL NOTES OR INSTRUCTIONS

Tool Information

ITEM NUMBER
QUANTITY (QUANTITIES) TO QUOTE
MATERIAL MACHINING

Tool Material (CIRCLE ONE)

CARBIDE	HSS	COOLANT THRU
PRE-FORM	SUPPLIED MAT'L	

Coating (CIRCLE ONE)

UNCOATED	ALTIN	TIN
TICN	NACO*	NACRO*
DLC	DIAMOND	ZRN

End Finish Broach (CIRCLE SHAPE, ADD NOTES)

SHAPE: HEX	SHAPE: RECTANGLE	LENGTH/WIDTH (X, Y)
EDGE RADIUS	EDGE CHAMFER	CHAMFER (DEGREE)
BACK TAPER (Y / N)		

End Finish Pins (ADD NOTES)

CIRCULAR (DIAMETER)

Quoting (MITGI USE ONLY)

MATERIAL STOCK OR SPECIAL ORDER
PRICING (BY QTY)
ESTIMATED SHIP DATE
MITGI CUSTOMER NUMBER
MITGI ACCOUNT MANAGER

GSS (MITGI USE ONLY)

PART DESCRIPTION CODE:	CUTTER DIAMETER/6
	# FLUTES/2 00
	TOOL TYPE CODE/4 BROA, PINS
	LOC/5
	SHANK DIAMETER/5
	OAL/3
	PRODUCT CODE: CA, CF

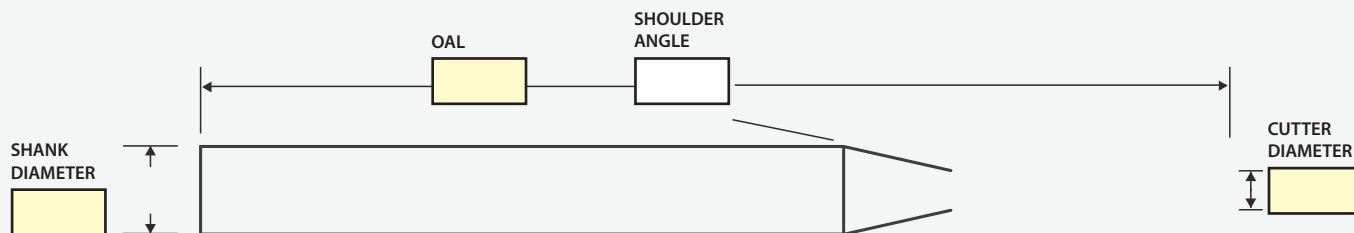

END FINISH (SKETCH END DESIGN)

TOLERANCES

.XX	± .010
.XXX	± .001
.XXXX	± .0005
Angular	± 1.0°

NOTES:

1. Tolerances are quoted with block tolerance unless noted (excluding OAL).
2. Shoulder angle is x° unless specified.
3. All dimensions are inches unless noted.
4. Use **highlighter** to designate cutting area.

Company Information

ORGANIZATION
PRIMARY CONTACT - NAME, EMAIL, PHONE
SECONDARY CONTACT - NAME, EMAIL, PHONE
ADDRESS
CITY, STATE, ZIP

Schedule and Production

DATE SUBMITTED
TARGET DELIVERY DATE
PREFERRED SHIPPING METHOD
LASER MARKING (Y / N)
SPECIAL NOTES OR INSTRUCTIONS

Tool Information

ITEM NUMBER
QUANTITY (QUANTITIES TO QUOTE)
MATERIAL MACHINING
NUMBER OF FLUTES
HELIX ANGLE (0° = STRAIGHT)
VARIABLE HELIX ANGLES (2 ANGLES NEEDED)

Tool Material (CIRCLE ONE)

CARBIDE	HSS	COOLANT THRU
PRE-FORM	SUPPLIED MAT'L	

Coating (CIRCLE ONE)

UNCOATED	ALTIN	TIN
TICN	NACRO®	NACRO®
DLC	DIAMOND	ZRN

Quoting (MITGI USE ONLY)

MATERIAL STOCK OR SPECIAL ORDER
PRICING (BY QTY)
ESTIMATED SHIP DATE
MITGI CUSTOMER NUMBER
MITGI ACCOUNT MANAGER

GSS (MITGI USE ONLY)

PART DESCRIPTION CODE:	CUTTER DIAMETER/6
	# FLUTES/2
	TOOL TYPE CODE/4 FMTL
	LOC/5
	SHANK DIAMETER/5
	OAL/3
	PRODUCT CODE: CA, CF